

Photodiode Characteristics and Applications

Silicon photodiodes are semiconductor devices responsive to high-energy particles and photons. Photodiodes operate by absorption of photons or charged particles and generate a flow of current in an external circuit, proportional to the incident power.

Photodiodes can be used to detect the presence or absence of minute quantities of light and can be calibrated for extremely accurate measurements from intensities below 1 pW/cm² to intensities above 100 mW/cm².

Silicon photodiodes are utilized in such diverse applications as :

- Spectroscopy
- Photography
- Analytical instrumentation
- Optical position sensors
- Beam alignment
- Surface characterization
- Laser range finders
- Optical communications
- Medical imaging instruments

PLANAR DIFFUSED SILICON PHOTODIODE CONSTRUCTION

Planar diffused silicon photodiodes are simply P-N junction diodes. A P-N junction can be formed by diffusing either a P-type impurity (anode), such as Boron, into a N-type bulk silicon wafer, or a N-type impurity, such as Phosphorous, into a P-type bulk silicon wafer. The diffused area defines the photodiode active area. To form an ohmic contact another impurity diffusion into the backside of the wafer is necessary. The impurity is an N-type for P-type active area and P-type for an N-type active area. The contact pads are deposited on the front active area on defined areas, and on the backside, completely covering the device. The active area is then passivated with an anti-reflection coating to reduce the reflection of the light for a specific predefined wavelength. The non-active area on the top is covered with a thick layer of silicon oxide. By controlling the thickness of bulk substrate, the speed and responsivity of the photodiode can be controlled. Note that the photodiodes, when biased, must be operated in the reverse bias mode, i.e. a negative voltage applied to anode and positive voltage to cathode.

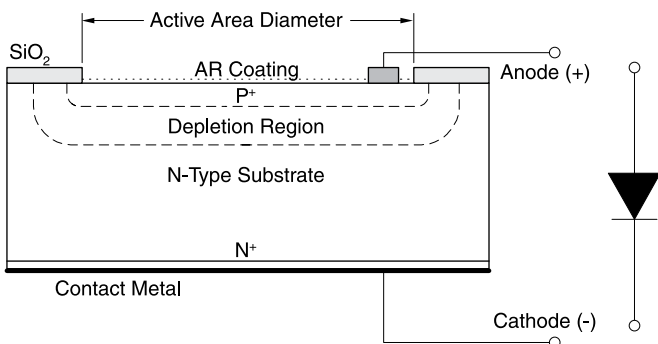

Figure 1. Planar diffused silicon photodiode

PRINCIPLE OF OPERATION

Silicon is a semiconductor with a band gap energy of 1.12 eV at room temperature. This is the gap between the valence band and the conduction band. At absolute zero temperature the valence band is completely filled and the conduction band is vacant. As the temperature increases, the electrons become excited and escalate from the valence band to the conduction band by thermal energy. The electrons can also be escalated to the conduction band by particles or photons with energies greater than 1.12eV, which corresponds to wavelengths shorter than 1100 nm. The resulting electrons in the conduction band are free to conduct current.

Due to concentration gradient, the diffusion of electrons from the N-type region to the P-type region and the diffusion of holes from the P-type region to the N-type region, develops a built-in voltage across the junction. The inter-diffusion of electrons and holes between the N and P regions across the junction results in a region with no free carriers. This is the depletion region. The built-in voltage across the depletion region results in an electric field with maximum at the junction and no field outside of the depletion region. Any applied reverse bias adds to the built in voltage and results in a wider depletion region. The electron-hole pairs generated by light are swept away by drift in the depletion region and are collected by diffusion from the undepleted region. The current generated is proportional to the incident light or radiation power. The light is absorbed exponentially with distance and is proportional to the absorption coefficient. The absorption coefficient is very high for shorter wavelengths in the UV region and is small for longer wavelengths (Figure 2). Hence, short wavelength photons such as UV, are absorbed in a thin top surface layer while silicon becomes transparent to light wavelengths longer than 1200 nm. Moreover, photons with energies smaller than the band gap are not absorbed at all.

(continued)

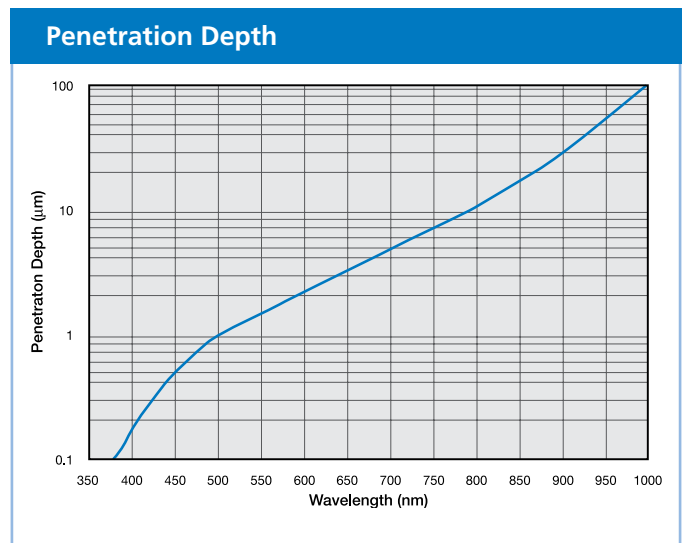

Figure 2. Penetration depth (1/e) of light into silicon substrate for various wavelengths.

ELECTRICAL CHARACTERISTICS

A silicon photodiode can be represented by a current source in parallel with an ideal diode (Figure 3). The current source represents the current generated by the incident radiation, and the diode represents the p-n junction. In addition, a *junction capacitance* (C_j) and a *shunt resistance* (R_{sh}) are in parallel with the other components. *Series resistance* (R_s) is connected in series with all components in this model.

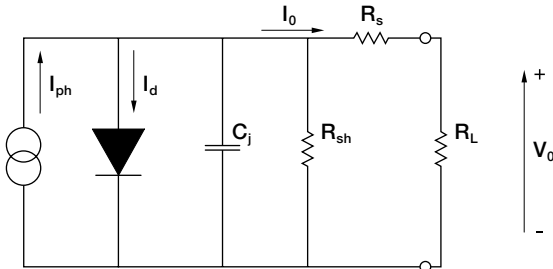

Figure 3. Equivalent Circuit for the silicon photodiode

Shunt Resistance, R_{sh}

Shunt resistance is the slope of the current-voltage curve of the photodiode at the origin, i.e. $V=0$. Although an ideal photodiode should have an infinite shunt resistance, actual values range from 10's to 1000's of Mega ohms. Experimentally it is obtained by applying ± 10 mV, measuring the current and calculating the resistance. Shunt resistance is used to determine the noise current in the photodiode with no bias (photovoltaic mode). For best photodiode performance the highest shunt resistance is desired.

Series Resistance, R_s

Series resistance of a photodiode arises from the resistance of the contacts and the resistance of the undepleted silicon (Figure 1). It is given by:

$$R_s = \frac{(W_s - W_d)\rho}{A} + R_c \quad (1)$$

Where W_s is the thickness of the substrate, W_d is the width of the depleted region, A is the diffused area of the junction, ρ is the resistivity of the substrate and R_c is the contact resistance. Series resistance is used to determine the linearity of the photodiode in photovoltaic mode (no bias, $V=0$). Although an ideal photodiode should have no series resistance, typical values ranging from 10 to 1000 Ω 's are measured.

Junction Capacitance, C_j

The boundaries of the depletion region act as the plates of a parallel plate capacitor (Figure 1). The junction capacitance is directly proportional to the diffused area and inversely proportional to the width of the depletion region. In addition, higher resistivity substrates have lower junction capacitance. Furthermore, the capacitance is dependent on the reverse bias as follows:

$$\begin{aligned} C_j &= \frac{\epsilon_{si}\epsilon_0 A}{\sqrt{2\epsilon_{si}\epsilon_0\mu\rho(V_A + V_{bi})}} \quad (2) \\ &= A\sqrt{\frac{\epsilon_{si}\epsilon_0}{2\mu\rho(V_A + V_{bi})}} \\ &= \frac{\epsilon_{si}\epsilon_0 A}{W_d} \end{aligned}$$

$$\text{Depletion Depth } W_d = \sqrt{2\epsilon_{si}\epsilon_0\mu\rho(V_A + V_{bi})}$$

Typical Capacitance vs. Reverse Bias

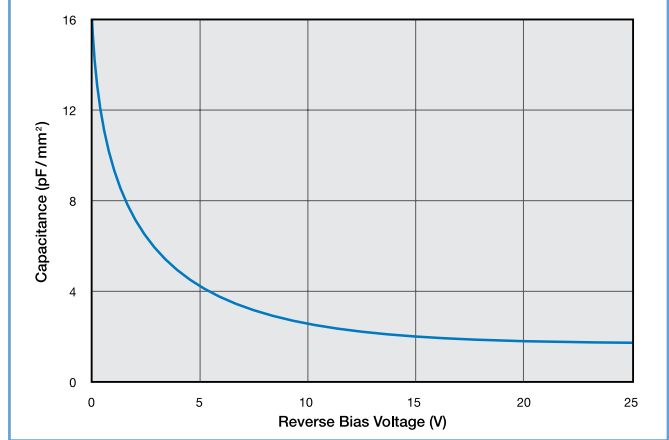

Figure 4. Capacitance of Photoconductive Devices versus Reverse Bias Voltage

where $\epsilon_0 = 8.854 \times 10^{-14}$ F/cm, is the permittivity of free space, $\epsilon_{si} = 11.9$ is the silicon dielectric constant, $\mu = 1400$ cm²/Vs is the mobility of the electrons at 300 K, ρ is the resistivity of the silicon, V_{bi} is the built-in voltage of silicon and V_A is the applied bias. Figure 4 shows the dependence of the capacitance on the applied reverse bias voltage. Junction capacitance is used to determine the speed of the response of the photodiode.

Rise / Fall Time and Frequency Response, t_r / t_f / f_{3dB}

The rise time and fall time of a photodiode is defined as the time for the signal to rise or fall from 10% to 90% or 90% to 10% of the final value respectively. This parameter can be also expressed as frequency response, which is the frequency at which the photodiode output decreases by 3dB. It is roughly approximated by:

$$t_r \approx \frac{0.35}{f_{3dB}} \quad (3)$$

There are three factors defining the response time of a photodiode:

1. t_{DRIFT} , the charge collection time of the carriers in the depleted region of the photodiode.
2. $t_{DIFFUSED}$, the charge collection time of the carriers in the undepleted region of the photodiode.
3. t_{RC} , the RC time constant of the diode-circuit combination.

t_{RC} is determined by $t_{RC} = 2.2 RC$, where R , is the sum of the diode series resistance and the load resistance ($R_s + R_L$), and C , is the sum of the photodiode junction and the stray capacitances ($C_j + C_s$). Since the junction capacitance (C_j) is dependent on the diffused area of the photodiode and the applied reverse bias (Equation 2), faster rise times are obtained with smaller diffused area photodiodes, and larger applied reverse biases. In addition, stray capacitance can be minimized by using short leads, and careful lay-out of the electronic components. The total rise time is determined by:

$$t_r = \sqrt{t_{DRIFT}^2 + t_{DIFFUSED}^2 + t_{RC}^2} \quad (4)$$

Generally, in photovoltaic mode of operation (no bias), rise time is dominated by the diffusion time for diffused areas less than 5 mm² and by RC time constant for larger diffused areas for all wavelengths. When operated in photoconductive mode (applied reverse bias), if the photodiode is fully depleted, such as high speed series, the dominant factor is the drift time. In non-fully depleted photodiodes, however, all three factors contribute to the response time.

Photodiode Characteristics

OPTICAL CHARACTERISTICS

Responsivity, R_λ

The responsivity of a silicon photodiode is a measure of the sensitivity to light, and it is defined as the ratio of the photocurrent I_p to the incident light power P at a given wavelength:

$$R_\lambda = \frac{I_p}{P} \quad (5)$$

In other words, it is a measure of the effectiveness of the conversion of the light power into electrical current. It varies with the wavelength of the incident light (Figure 5) as well as applied reverse bias and temperature.

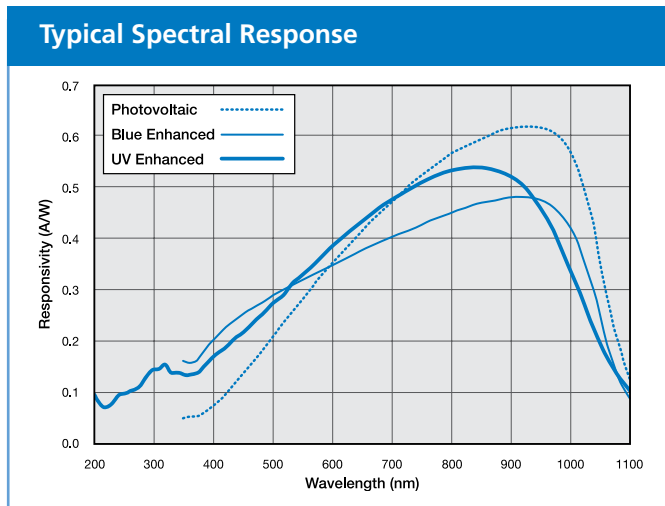

Figure 5. Typical Spectral Responsivity of Several Different Types of Planar Diffused Photodiodes

Responsivity increases slightly with applied reverse bias due to improved charge collection efficiency in the photodiode. Also there are responsivity variations due to change in temperature as shown in figure 6. This is due to decrease or increase of the band gap, because of increase or decrease in the temperature respectively. Spectral responsivity may vary from lot to lot and it is dependent on wavelength. However, the relative variations in responsivity can be reduced to less than 1% on a selected basis.

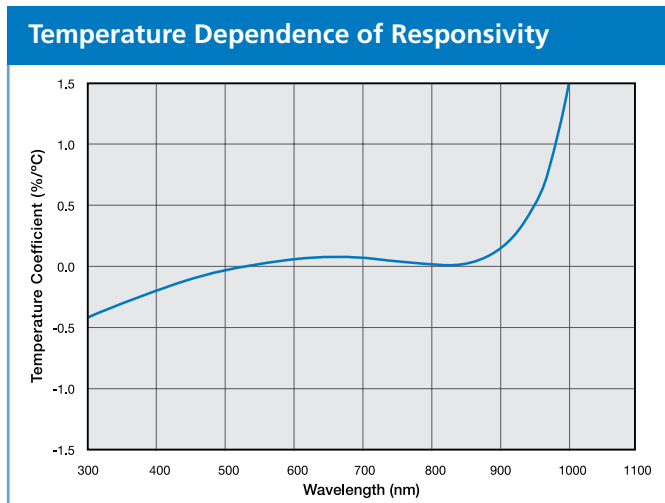

Figure 6. Typical Temperature Coefficient of Responsivity For Silicon Photodiode

Quantum Efficiency, Q.E.

Quantum efficiency is defined as the fraction of the incident photons that contribute to photocurrent. It is related to responsivity by:

$$\begin{aligned} Q.E. &= \frac{R_\lambda \text{ Observed}}{R_\lambda \text{ Ideal}} \quad (6) \\ &= R_\lambda \frac{hc}{\lambda q} \\ &= 1240 \frac{R_\lambda}{\lambda} \end{aligned}$$

where $h=6.63 \times 10^{-34}$ J-s, is the Planck constant, $c=3 \times 10^8$ m/s, is the speed of light, $q=1.6 \times 10^{-19}$ C, is the electron charge, R_λ is the responsivity in A/W and λ is the wavelength in nm.

Non-Uniformity

Non-uniformity of response is defined as variations of responsivity observed over the surface of the photodiode active area with a small spot of light. Non-uniformity is inversely proportional to spot size, i.e. larger non-uniformity for smaller spot size.

Non-Linearity

A silicon photodiode is considered linear if the generated photocurrent increases linearly with the incident light power. Photocurrent linearity is determined by measuring the small change in photocurrent as a result of a small change in the incident light power as a function of total photocurrent or incident light power. Non-Linearity is the variation of the ratio of the change in photocurrent to the same change in light power, i.e. $\Delta I/\Delta P$. In another words, linearity exhibits the consistency of responsivity over a range of light power. Non-linearity of less than $\pm 1\%$ are specified over 6-9 decades for planar diffused photodiodes. The lower limit of the photocurrent linearity is determined by the noise current and the upper limit by the series resistance and the load resistance. As the photocurrent increases, first the non-linearity sets in, gradually increasing with increasing photocurrent, and finally at saturation level, the photocurrent remains constant with increasing incident light power. In general, the change in photocurrent generated for the same change in incident light power, is smaller at higher current levels, when the photodetector exhibits non-linearity. The linearity range can slightly be extended by applying a reverse bias to the photodiode.

(continued)

I-V CHARACTERISTICS

The current-voltage characteristic of a photodiode with no incident light is similar to a rectifying diode. When the photodiode is forward biased, there is an exponential increase in the current. When a reverse bias is applied, a small reverse saturation current appears. It is related to dark current as:

$$I_D = I_{SAT} (e^{\frac{qV_A}{k_B T}} - 1) \quad (7)$$

where I_D is the photodiode dark current, I_{SAT} is the reverse saturation current, q is the electron charge, V_A is the applied bias voltage, $k_B = 1.38 \times 10^{-23}$ J / K, is the Boltzmann Constant and T is the absolute temperature (273 K = 0 °C).

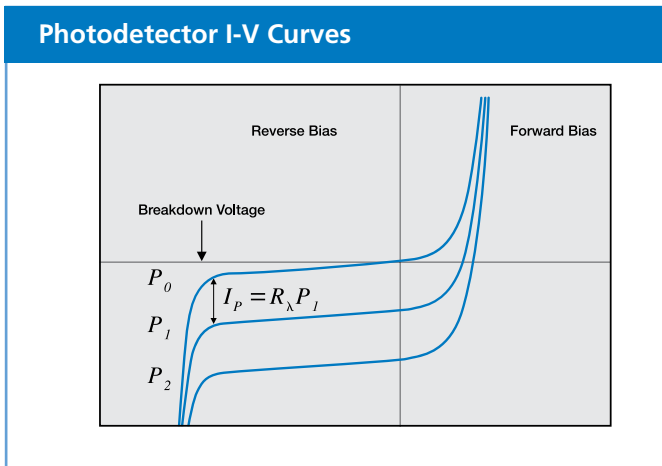

Figure 7. Characteristic I-V Curves of an OSI Optoelectronics photodiode for Photoconductive and Photovoltaic modes of operation. P_0 - P_2 represent different light levels.

This relationship is shown in figure 7. From equation 7, three various states can be defined:

- $V = 0$, In this state, the dark current $I_p = 0$.
- $V = +V$, In this state the current increases exponentially. This state is also known as forward bias mode.
- $V = -V$, When a very large reverse bias is applied to the photodiode, the dark current becomes the reverse saturation current, I_{SAT} .

Illuminating the photodiode with optical radiation, shifts the I-V curve by the amount of photocurrent (I_p). Thus:

$$I_{TOTAL} = I_{SAT} (e^{\frac{qV_A}{k_B T}} - 1) - I_p \quad (8)$$

where I_p is defined as the photocurrent in equation 5.

As the applied reverse bias increases, there is a sharp increase in the photodiode current. The applied reverse bias at this point is referred to as breakdown voltage. This is the maximum applied reverse bias, below which, the photodiode should be operated (also known as maximum reverse voltage). Breakdown voltage, varies from one photodiode to another and is usually measured, for small active areas, at a dark current of 10 μ A.

NOISE

In a photodiode, two sources of noise can be identified; Shot noise and Johnson noise:

Shot Noise

Shot noise is related to the statistical fluctuation in both the photocurrent and the dark current. The magnitude of the shot noise is expressed as the root mean square (rms) noise current:

$$I_{sn} = \sqrt{2q(I_p + I_D)\Delta f} \quad (9)$$

Where $q = 1.6 \times 10^{-19}$ C, is the electron charge, I_p is the photogenerated current, I_D is the photodetector dark current and Δf is the noise measurement bandwidth. Shot noise is the dominating source when operating in photoconductive (biased) mode.

Thermal or Johnson Noise

The shunt resistance in a photodetector has a Johnson noise associated with it. This is due to the thermal generation of carriers. The magnitude of this generated noise current is:

$$I_{jn} = \sqrt{\frac{4k_B T \Delta f}{R_{SH}}} \quad (10)$$

Where $k_B = 1.38 \times 10^{-23}$ J/K, is the Boltzmann Constant, T , is the absolute temperature in degrees Kelvin (273 K = 0 °C), Δf is the noise measurement bandwidth and R_{SH} , is the shunt resistance of the photodiode. This type of noise is the dominant current noise in photovoltaic (unbiased) operation mode.

Note: All resistors have a Johnson noise associated with them, including the load resistor. This additional noise current is large and adds to the Johnson noise current caused by the photodetector shunt resistance.

Total Noise

The total noise current generated in a photodetector is determined by:

$$I_{tn} = \sqrt{I_{sn}^2 + I_{jn}^2} \quad (11)$$

Noise Equivalent Power (NEP)

Noise Equivalent Power is the amount of incident light power on a photodetector, which generates a photocurrent equal to the noise current. NEP is defined as:

$$NEP = \frac{I_{tn}}{R_\lambda} \quad (12)$$

Where R_λ is the responsivity in A/W and I_{tn} is the total noise of the photodetector. NEP values can vary from 10^{-11} W/ \sqrt Hz for large active area photodiodes down to 10^{-15} W/ \sqrt Hz for small active area photodiodes.

(continued)

Photodiode Characteristics

TEMPERATURE EFFECTS

All photodiode characteristics are affected by changes in temperature. They include shunt resistance, dark current, breakdown voltage, responsivity and to a lesser extent other parameters such as junction capacitance.

Shunt Resistance and Dark Current:

There are two major currents in a photodiode contributing to dark current and shunt resistance. Diffusion current is the dominating factor in a photovoltaic (unbiased) mode of operation, which determines the shunt resistance. It varies as the square of the temperature. In photoconductive mode (reverse biased), however, the drift current becomes the dominant current (dark current) and varies directly with temperature. Thus, change in temperature affects the photodetector more in photovoltaic mode than in photoconductive mode of operation.

In photoconductive mode the dark current may approximately double for every 10 °C increase change in temperature. And in photovoltaic mode, shunt resistance may approximately double for every 6 °C decrease in temperature. The exact change is dependent on additional parameters such as the applied reverse bias, resistivity of the substrate as well as the thickness of the substrate.

Breakdown Voltage:

For small active area devices, by definition breakdown voltage is defined as the voltage at which the dark current becomes 10µA. Since dark current increases with temperature, therefore, breakdown voltage decreases similarly with increase in temperature.

Responsivity:

Effects of temperature on responsivity is discussed in the “Responsivity” section of these notes.

BIASING

A photodiode signal can be measured as a voltage or a current. Current measurement demonstrates far better linearity, offset, and bandwidth performance. The generated photocurrent is proportional to the incident light power and it must be converted to voltage using a transimpedance configuration. The photodiode can be operated with or without an applied reverse bias depending on the application specific requirements. They are referred to as “Photoconductive” (biased) and “Photovoltaic” (unbiased) modes.

Photoconductive Mode (PC)

Application of a reverse bias (i.e. cathode positive, anode negative) can greatly improve the speed of response and linearity of the devices. This is due to increase in the depletion region width and consequently decrease in junction capacitance. Applying a reverse bias, however, will increase the dark and noise currents. An example of low light level / high-speed response operated in photoconductive mode is shown in figure 8.

In this configuration the detector is biased to reduce junction capacitance thus reducing noise and rise time (t_r). A two stage amplification is used in this example since a high gain with a wide bandwidth is required. The two stages include a transimpedance pre-amp for current- to-voltage conversion and a non-inverting amplifier for voltage amplification. Gain and bandwidth (f_{3dB Max}) are directly determined by R_F, per equations (13) and (14). The gain of the second stage is approximated by 1+ R₁ / R₂. A feedback capacitor (C_F) will limit the frequency response and avoids gain peaking.

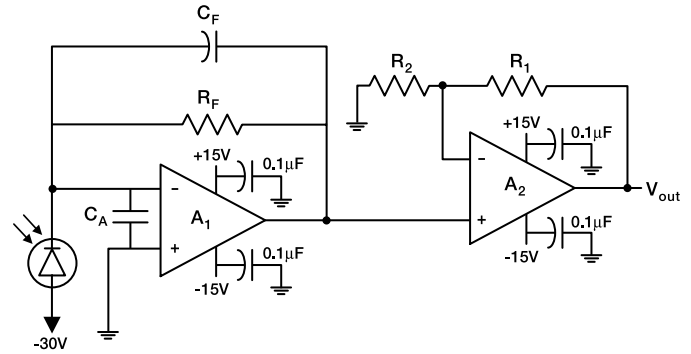

Figure 8. Photoconductive mode of operation circuit example: Low Light Level / Wide Bandwidth

$$f_{3dBMax} [Hz] = \sqrt{\frac{GBP}{2\pi R_F (C_J + C_F + C_A)}} \quad (13)$$

Where GBP is the Gain Bandwidth Product of amplifier (A₁) and C_A is the amplifier input capacitance.

$$Gain(V/W) = \frac{V_{OUT}}{P} = R_F \left(1 + \frac{R_1}{R_2}\right) R_A \quad (14)$$

In low speed applications, a large gain, e.g. >10MΩ can be achieved by introducing a large value (R_F) without the need for the second stage.

Typical components used in this configuration are:

Amplifier :	OPA-637, OPA-846, OPA-847, or similar
R _F :	1 to 10 KΩ Typical, depending on C _J
R ₁ :	10 to 50 kΩ
R ₂ :	0.5 to 10 kΩ
C _F :	0.2 to 2 pF

In high speed, high light level measurements, however, a different approach is preferred. The most common example is pulse width measurements of short pulse gas lasers, solid state laser diodes, or any other similar short pulse light source. The photodiode output can be either directly connected to an oscilloscope (Figure 9) or fed to a fast response amplifier. When using an oscilloscope, the bandwidth of the scope can be adjusted to the pulse width of the light source for maximum signal to noise ratio. In this application the bias voltage is large. Two opposing protection diodes should be connected to the input of the oscilloscope across the input and ground.

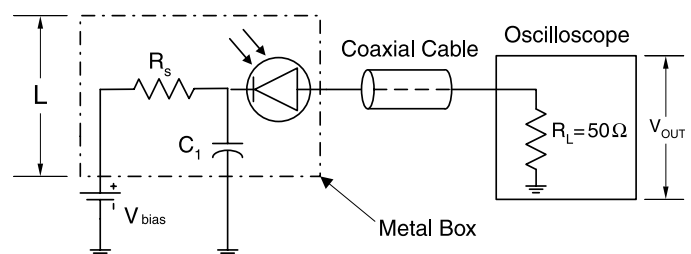

Figure 9. Photoconductive mode of operation circuit example: High Light Level / High Speed Response

(continued)

To avoid ringing in the output signal, the cable between the detector and the oscilloscope should be short (i.e. < 20cm) and terminated with a 50 ohm load resistor (R_L). The photodiode should be enclosed in a metallic box, if possible, with short leads between the detector and the capacitor, and between the detector and the coaxial cable. The metallic box should be tied through a capacitor (C_1), with lead length (L) less than 2 cm, where $R_L C_1 > 10 \tau$ (τ is the pulse width in seconds). R_S is chosen such that $R_S < V_{BIAS} / 10 I_{PDC}$, where I_{PDC} is the DC photocurrent. Bandwidth is defined as $0.35 / \tau$. A minimum of 10V reverse bias is necessary for this application. Note that a bias larger than the photodiode maximum reverse voltage should not be applied.

Photovoltaic Mode (PV)

The photovoltaic mode of operation (unbiased) is preferred when a photodiode is used in low frequency applications (up to 350 kHz) as well as ultra low light level applications. In addition to offering a simple operational configuration, the photocurrents in this mode have less variations in responsivity with temperature. An example of an ultra low light level / low speed is shown in figure 10.

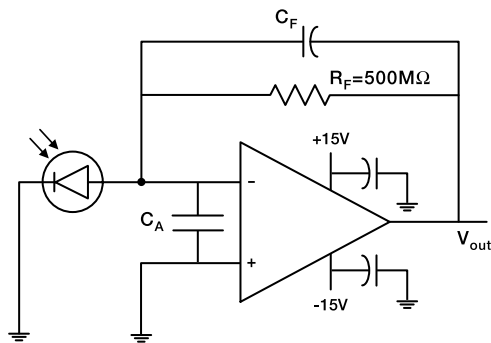

Figure 10. Photovoltaic mode of operation circuit example: Ultra low level light / low speed

In this example, a FET input operational amplifier as well as a large resistance feedback resistor (R_F) is considered. The detector is unbiased to eliminate any additional noise current. The total output is determined by equation (15) and the op-amp noise current is determined by R_F in equation (16):

$$V_{OUT} = I_P \times R_F \quad (15)$$

$$I_N \left[\frac{A_{rms}}{\sqrt{Hz}} \right] = \sqrt{\frac{4kT}{R_F}} \quad (16)$$

where $k=1.38 \times 10^{-23}$ J/K and T is temperature in K.

For stability, select C_F such that

$$\sqrt{\frac{GBP}{2\pi R_F (C_J + C_F + C_A)}} > \frac{1}{2\pi R_F C_F} \quad (17)$$

Operating bandwidth, after gain peaking compensation is:

$$f_{OP} [Hz] = \frac{1}{2\pi R_F C_F} \quad (18)$$

Some recommended components for this configuration are:

Amplifier :	OPA111, OPA124, OPA627 or similar
R_F :	500 MΩ

These examples or any other configurations for single photodiodes can be applied to any of OSI Optoelectronics' monolithic, common substrate liner array photodiodes. The output of the first stage pre-amplifiers can be connected to a sample and hold circuit and a multiplexer. Figure 11 shows the block diagram for such configuration.

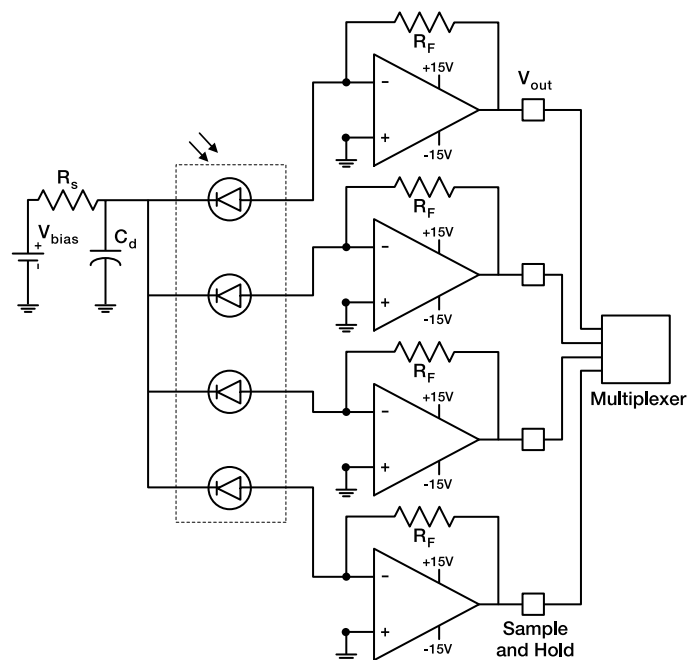

Figure 11. Circuit example for a multi-element, common cathode array