

WP512

Imaging Spectral Colorimeter



The all-in-one production tester for displays, lighting, and more.

Description

The [WP512](#) is a unique imaging colorimeter solution comprising an integrated high-resolution camera and an internal reference spectroradiometer.

Consistently beautiful displays and lighting require accurate and precise measurement equipment on the production line. The WP512 has superb performance without the hassle and cost of multiple discrete instruments. Everything needed is in one compact package with one power connection and one GigE connection.

All display types and sizes

With a wide assortment of lenses available, from microscope objectives to wide-angle, the WP512 is configurable for measurements of any display size, from microdisplays to smartwatches, tablets, TVs, or cinema walls. The system supports electronic or manual lenses from 24 to 100mm focal length, plus fixed focus microscope lenses up to 10x magnification. In addition, our unique Conometer[®] lens for viewing angle measurements out to +/-80 degrees and a periscope lens for analysis of augmented and virtual reality near-eye displays are available.

Key Features

- 12.3 MP imaging
- Integrated spot spectroradiometer
- 0.001 cd/m² sensitivity
- Independent ND filters for camera and spectroradiometer
- Low polarization
- Automatic dark measurements
- EF lenses
- No beam splitter

Applications

- Flat panel displays
- Near eye displays
- Lighting
- LED arrays

WP512 Imaging Spectral Colorimeter

Measurement principle

The instrument design optimizes throughput and sensitivity by sending all the light to either the camera or to the spectroradiometer — resulting in significant takt time improvements when low light measurements are required.

Key to the WP512's unique capability is the high-speed linear translation stage. The stage has multiple positions for imaging light with the RGB camera or with the spectroradiometer. In addition, there is standard filtering up to ND1 in the RGB camera path and up to ND2 in the spectrometer path. Low luminance measurements are crucial for takt time optimization in many production scenarios. Having higher throughput, the WP512 is two times faster at the bottleneck measurements than comparable beam-splitter solutions that share the light with two or more focal planes. The neutral density filter options accommodate a wide range of light measurements. Users can measure very bright scenes; or attenuate to increase the optimal exposure time. For example, although the camera and spectrometer can have sub-millisecond exposure times, a display modulated at 30Hz may be best measured at exposures of 33.3ms. Additionally, the method has very low polarization dependence and minimal chromatic and geometrical distortion — both critical parameters of measurement accuracy.

Conveniently, when the camera is imaging, the spectrometer is shuttered and vice-versa. In this way, frequent dark measurement correction is available in production without affecting takt time.

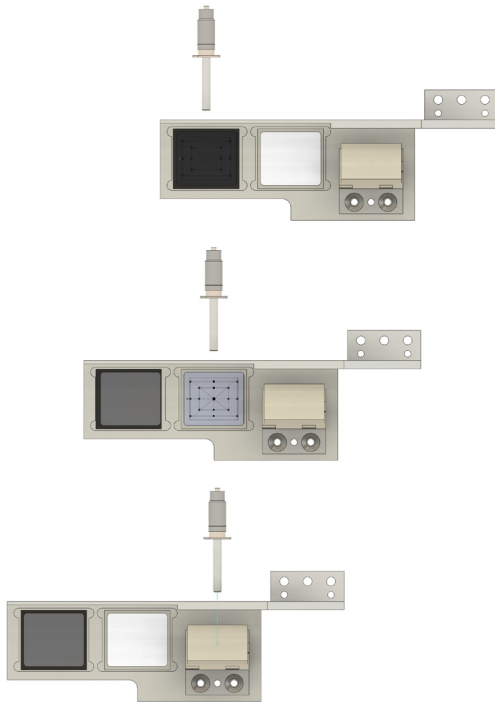

The fiber is fixed and the stage moves left and right. At top an ND1 is in front of the imager. Middle, no ND in front of the imager. Bottom a prism deflects light to the fiber.

AR/VR display testing

The periscope design [XR1 Near Eye Display \(NED\) Lens](#) provides optimal test performance for displays up to 60 degrees horizontal or vertical Field of View. The periscope design ensures the lens readily fits into final assemblies of glasses, headsets, and helmets. Under different stimuli, human visual accommodation results in varying pupil diameters. For that reason, the entrance pupil aperture is adjustable from 1.5 to 5.0 mm.



Distortion corrected

A menu-driven registration and distortion correction assistant allows users to correct for lens distortions. Once the correction is applied, any distortions in the display under test are revealed and can be analyzed.

Viewing angle

The [Conometer® lens](#) enables viewing angle measurements of flat panel displays and backlights.



Spectral performance

The integrated, low noise CMOS spectrometer is optimized for high performance color measurements. The combination of low optical stray light and high dynamic range using exposure time stacking enables superb color measurements.

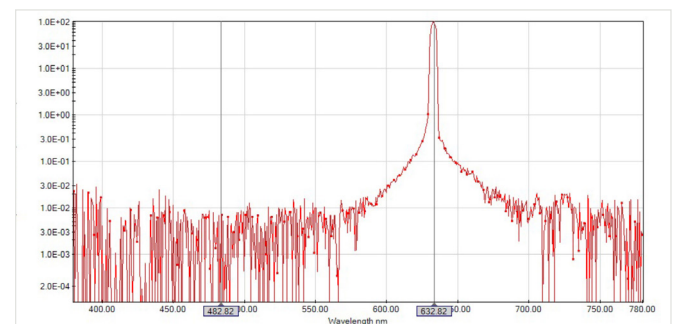

HeNe laser spectrum plotted in log scale showing $<1E-4$ stray light

Comprehensive solution for production testing

The WP512 has all the right features for deployment in production. The high accuracy spectroradiometer and camera have hardware triggers to synchronize the measurement with other equipment in the test setup. The camera uses advanced thermal management to keep the sensor cool and sensitive. Air filters attach to the fan vents to help keep dust out of the electronics area. The software automatically matches the electronic lens to the calibration file. There are also various system LEDs and beeps to confer the instrument status.

Additionally, Westboro Photonics also offers on-site recalibration software to minimize production downtime and other costs related to off-site calibration. Westboro's Photonics' network of international distributors and local recalibration labs provide additional support levels.

Uniformity

When evaluating displays and lighting for color non-uniformities, measurements should be constrained to white or unsaturated scenes. As a general rule, the RGB imager information is less useful when the ratio of signal from any primaries exceeds 4:1. Fortunately though, if there are non-uniformities in a display set to red, green or blue, those same issues are typically also evident when the display is set to white, and 2-D measurements of gamut points may be omitted in production. Alternatively, if color uniformity of saturated colors is required, a tristimulus colorimeter such as the [WP6 Series](#) or [MCIC](#) is recommended instead.

Flat panel display testing

With our comprehensive display performance and defect tests, users can readily deploy solutions to production with minimal engineering effort. Performance tests include luminance and color uniformity, gamma, gamut, contrast, and viewing angle. Defect tests include pixel and line defects, mura, dust and debris, etc.

Visit our website for more information about [Photometrica® software capabilities](#) to measure and analyze displays, lighting and more.

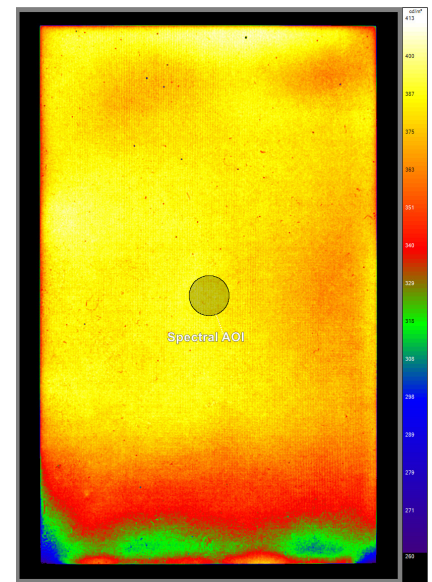
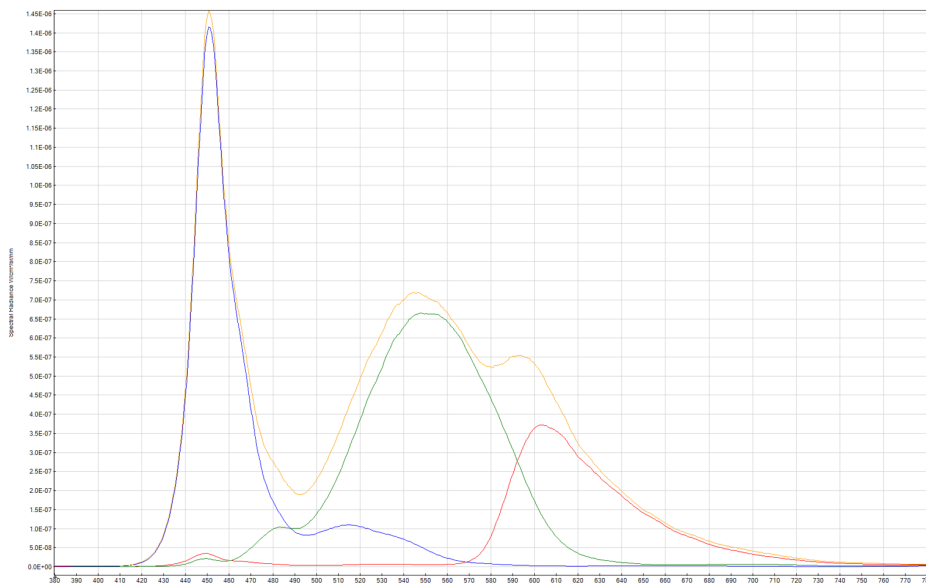

Partial screenshot of Photometrica® software showing example of 2D luminance image of a smartphone display, and corresponding spectral data from the measurement spot.

WP512 Imaging Spectral Colorimeter

TECHNICAL SPECIFICATIONS*	
2D Measurements	Luminance, chromaticity
Spot Measurements	Spectrum, luminance, chromaticity, radiance etc.
CAMERA	
Effective resolution (h x v)	4096 x 3000 pixels (12.3 megapixels)
Pixel size	3.45 μm x 3.45 μm
Dynamic range	70 dB, >100dB with HDR imaging
AD converter	12 bit
Luminance range 2D ^{2,4}	0.0013 cd/m ² – 2.9 E+5 cd/m ²
Precision for luminance and chromaticity, u', v' ⁵	$\pm 0.05\%$ ± 0.00004
SPECTRORADIOMETER	
Wavelength range	380-780 nm
Resolution bandpass	4.2 nm
Data point interval	0.57 nm
Wavelength accuracy	0.5 nm
Stray light, 8 bandwidths from HeNe laser	3 E-5
Spectral spot area; diameter	10554 pixels; 116 pixels
Luminance range ^{3,4}	0.11 cd/m ² – 3.0 E+6 cd/m ²
Precision ⁵	$\pm 0.1\%$ for Y; ± 0.0001 for u', v'
Accuracy of spot spectroradiometer ⁶	$\pm 3.5\%$ for Y; ± 0.0015 for u', v'
Polarization sensitivity ⁷	$\pm 0.1\%$ for Y; ± 0.0001 for u', v'
MEASUREMENT TIME⁸	
Measurement time camera only	0.6 s
Measurement time spectrometer only	0.1 s
Measurement time hybrid mode	1.8 s
GENERAL	
Operating System	Windows 10/11 (64 bit)
Dimensions (l x w x h) ¹	190 mm x 190 mm x 100 mm
Height of optical axis above camera mount	102 mm
Interface	Gigabit Ethernet
Weight	3.9 kg without lens
Power supply	12 V, 4A max
Operating temperature range	15 – 35 °C, 0-85% humidity, non-condensing

ORDERING SPECIFICATIONS	
WP512 Imaging Spectral Colorimeter	
OPTIONS	
-02	Manual EF lens mount
-06	Electronic EF lens mount
ELECTRONIC LENSES	
LS-24-1.4L-EF	24 mm
LS-35-2.0-EF	35 mm
LS-50-1.2L-EF	50 mm
LS-100-2.8L-EF	100 mm
MANUAL LENSES	
LS-24-1.4-EF	24 mm
LS-35-2.0-EF	35 mm
LS-50-1.2L-EF	50 mm
LS-100-2.8L-EF	100 mm
LS-2X-EF	2x microscope
LS-5X-EF	5x microscope
LS-10X-EF	10x microscope
LS-Cono-EF	160° Conometer Viewing Angle
LS-NED-EF	XR1 Near Eye Display

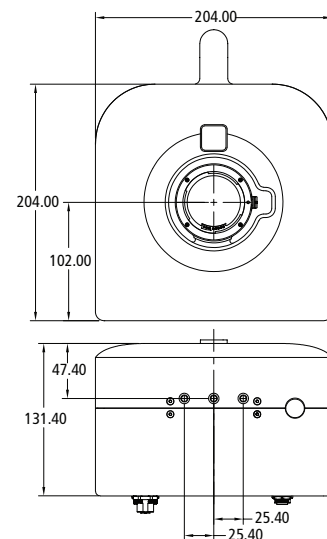

* Specifications are preliminary and unless specified otherwise, are for a 116 pixel diameter spot in the center of the image, 50 mm lens at iris F1.2 at 1 meter working distance and measuring illuminant A. Accuracy and precision specifications are at 23°C +/- 2°C after calibration and after 30 minutes of warmup. Specifications are subject to change.

- 1 Excluding lens and handle.
- 2 Imager using exposure times from 260 μs to 8.2 s and with internal ND0 and ND1 and iris settings F1.4, F2.8 and F5.6.
- 3 Spectrometer using exposure times from 0.5 ms to 8.2 s, without averaging, and with internal ND0, ND1, ND2, and ND3 and with calibrated iris positions F1.2, F2.8, and F5.6. Averaging up to 100 measurements can improve noise level by 10x and improve precision.
- 4 Lower measurement limit based on a single exposure at 8.2 s exposure time and a signal to noise ratio of 10:1. Averaging up to 100 measurements can improve noise level by 10x and improve precision.

- 5 2σ deviation for repeat measurements (Y \approx 100 cd/m² using auto single or auto-HDR captures). Averaging up to 100 measurements can improve precision.
- 6 Immediately after calibration and relative to standard for measurements with HDR and adequate signal to noise.
- 7 Maximum deviation from average when measuring broadband, linear polarized light at varying polarization angles.
- 8 Measurement period using the SDK; using minimum exposure times and a fast PC.

Westboro Photonics continually pursues improvements to the instruments. Specification adjustments, errata or omissions do not constitute grounds for compensation.